

# Frascold<sup>®</sup>

## RTS/NR

**Frascold semi-hermetic screw compressors**  
suitable for refrigeration

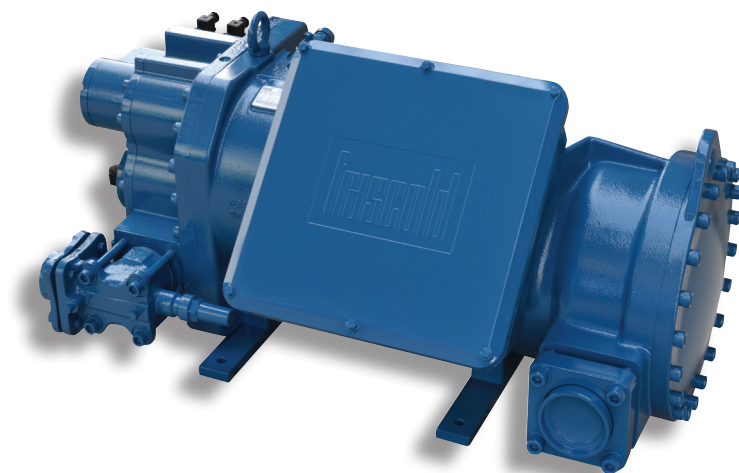

## RTS SERIES

New compressors characterized by innovative and compact design, suitable for commercial or industrial applications, either at medium or at low evaporating temperatures. Of up to 6 compressors the parallel compound is allowed. Outstanding performances and efficiency both with and without economizer. Particularly recommended whenever low noise units are required. Due to the multi-function automatic electronic control and to the exclusive oil management system, this series is also extremely reliable.

All models can be driven by an external VFD in order to adjust the cooling capacity to the actual thermal loads with the highest efficiencies and precision.

All models are characterized by:

### High precision

Through our extensive experience in all refrigeration applications we were able to develop a compressor series characterized by high COP in all its application envelope, making it possible to optimize the efficiency of the systems in which these compressors are used.

### Capacity control

The precise capacity control system allows to adjust the amount of refrigerant mass flow to be compressed according to the actual thermal load.

### High flexibility

Their different versions and complete list of accessories make it possible to use this compressors' series in very wide application ranges with all traditional HFC- or HCFC-based refrigerants and with the new low-GWP ones.

### Easy installation and maintenance

Thanks to their smart design, both their installation and maintenance turn out to be extremely simple.

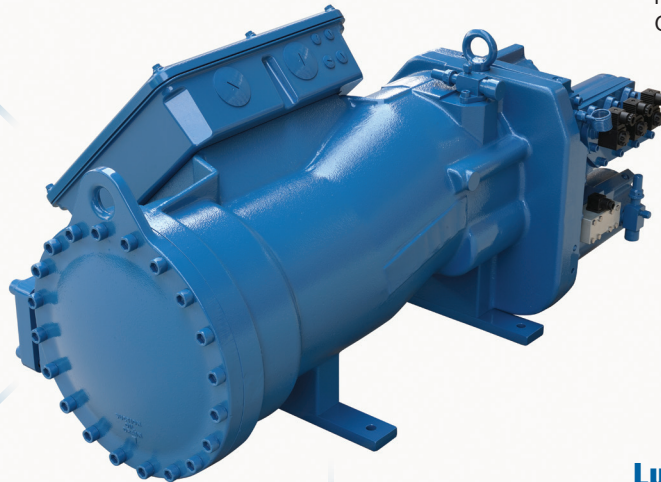

### Economizer

To increase the cooling capacity, all models have a special connection point for the external sub-cooling of part of the refrigerant.

### Low noise

The mechanical optimization and the fine workmanship assure extremely low noise levels and reduced vibrations at all possible working conditions.

### Lubrication circuit / oil injection

The essential lubrication function is assured by a suitable oil circuit that reduces all possible internal frictions and cools down the components subjected to wear.

### Total reliability

Thanks to their sturdiness and precise execution and thanks to the high quality of their components and the respect of the highest production quality standards, these compressors are characterized by long life even at the most severe working conditions.

# MODELS RANGE

## High and medium temperature - Motor 1

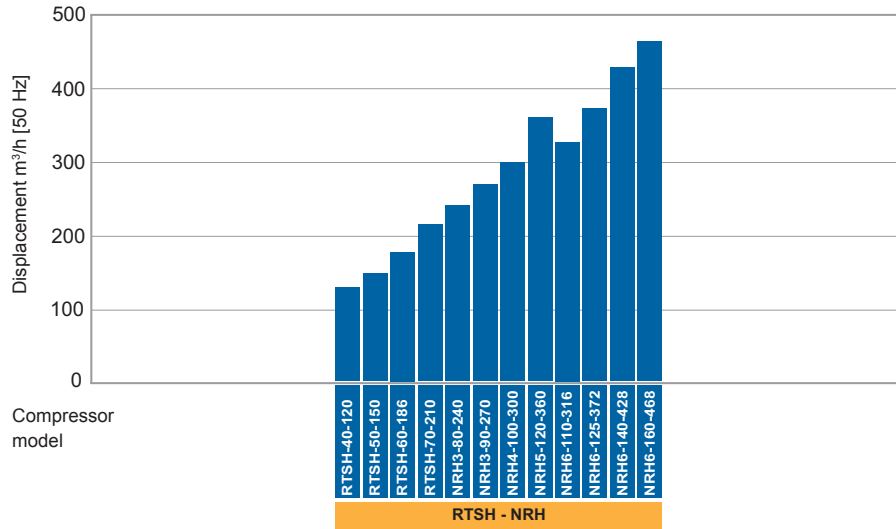

## Low temperature - Motor 2

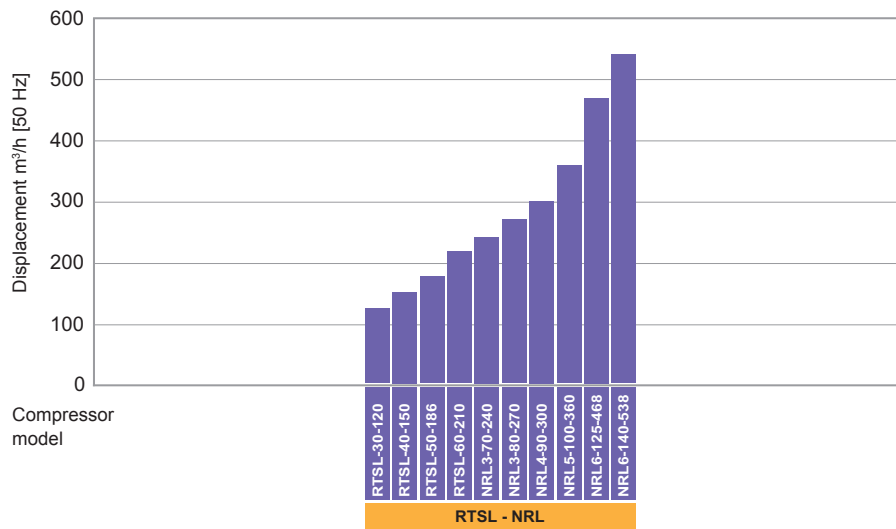

## R134a application - Motor 3

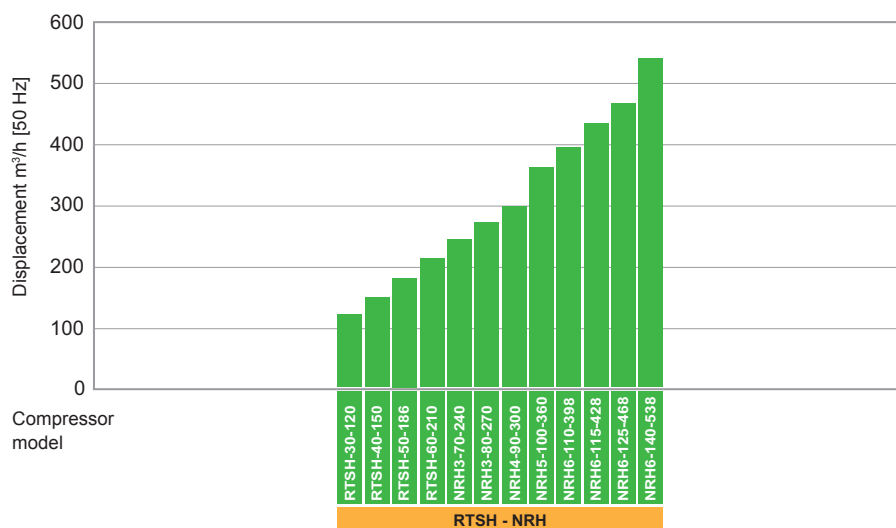

# FEATURES

The compressors of RTS and NR series are meant for all refrigeration applications, both at medium and low evaporating temperatures, and also for the parallel compound in multi-compressor systems. The max cooling capacity reaches 375 kW and there are a good total of 32 models with a displacement range of 120+538 m<sup>3</sup>/h at 50Hz.

These compressors have been designed for long continuous working without structural failures and with reduced maintenance activities. Their efficiency is higher compared to the market standard and their use is particularly recommended for applications where low noise and vibrations are required.

The accurate design together with the total "made-in-Italy" production and the systematic total quality checks grant outstanding performances and reliability.

The wide range consists of 3 different executions to cover at best all possible applications:

- Models RTSH / NRH with motor version 1 optimized for medium or high evaporating temperature applications with all kind of common refrigerants.
- Models RTSL / NRL with motor version 2 optimized for low evaporating temperature applications with all kind of common refrigerants.
- Models RTSH / NRH with motor version 3 optimized for medium or high evaporating temperature applications with R134a.

## Efficiency

Twin screw technology totally designed by Frascold, with innovative helical male and female profiles to grant the maximum performances at all pressures, temperatures and refrigerant velocities within the admitted application range. Specifically there are a 5-lobe male rotor and a 6-lobe female rotor.

High efficiency part-winding electrical motor, optimized for the different refrigerants and applications.

The motor is thermally protected by 6 PTC sensors embedded onto the wirings and its cooling is granted by the suction gas while it crosses its wide heat transfer channels.

High efficiency at partial loads.

Economizer functioning allowed.

Inverter technology allowed.

## Reliability

High strength.

Internal circuit designed to facilitate the liquid evaporation on suction side whenever present.

Reduced internal pressure drops of the refrigerants.

High volumetric compression ratio thanks to a fine-tuned management of the oil film between the rotors.

Special bearing kit of big diameter for a better resistance to the high radial loads typical of refrigeration application. An extra bearing against transient reverse rotation of the rotors is also included. All bearings have been selected for high duty and long life (50.000 hours as average working life)

Automatic start unloader system.

## Electronic protection module

All models are supplied with an electronic protection module that is connected to the PTC chain embedded onto the electrical motor wirings and to the discharge temperature sensor.

Together with the motor and discharge temperatures, this module monitors:

- The phase loss.
- The correct rotation direction at start-up.
- The max number of starts up per hour (max 6 for hour).

## Oil injection system

The oil injection kit is provided as standard and consist of:

Oil filter, oil flow switch with its electronic control module, solenoid valve, oil sight glass.

For NR\_6 models, being the oil flow switch and the oil filter integrated, the kit consist of just the solenoid valve and the oil sight glass.

## Low noise and vibrations

The housing of the compressors provides with reduced noise levels; plus the innovative profile of the screws and the special bearings used enhance this quality and make these compressors way more silent than those offered in the market.

## Capacity control

RTS series: 2 steps (50-100%).

NR series: 3 steps (50-75/100%).

## Applications

R134a, R404A, R507A, R407F, R407A, R407C, R22, other refrigerants upon request.

Compressors designed for very low evaporating temperatures applications (down to -50°C). With or without economizer.

## Economizer functioning

All models can work with economizer circuit.

The cooling capacity and the efficiency get significantly higher.

The compression process get closer to the ideal one.

# SUPPLY

The standard delivery turns out to be one of the most complete and we found a wide range of options.



## Standard supply

Capacity control, start unloader system.  
 Suction shut-off valve, discharge shut-off valve with integrated check valve.  
 Internal safety valve, electronic protection module, discharge temperature sensor.  
 Oil injection kit (oil flow switch, oil filter, solenoid valve, oil sight glass).  
 IP65 class electrical box, vibration dampers.

## Options

Oil separator, different sizes available.  
 Air-cooled oil cooler, different sizes available.  
 Water-cooled oil cooler, different sizes available.  
 Oil filter clogging pressure switch (NR\_6 models).  
 Kit for ECO or liquid injection connection.

## Standard performances

The given performances data are in line with the European directive EN12900, with no liquid subcooling.  
 While comparing models of other brands it is necessary to consider that with 5K or 8,3K subcooling values the cooling capacity and related COP are higher. In any case refer to Frascold selection software for the performances data at different working conditions.

## Performances with economizer

Whenever the economizer circuit is chosen, the given performances consider the subcooling.  
 In accord to the European directive EN12900, the liquid temperature is set 5K higher than the inlet saturated temperature at the economizer.

## Performances ASERCOM certified

ASERCOM, of which Frascold is a member, in order to promote performances and safety standards for the compressors has defined the performances' certification procedure.  
 The compressor's certification guarantees that the performances given by the compressor manufacturer are those measured in accord to the European directive EN12900.  
 Models with certified performances are marked with "ASERCOM Certified Product" logo.  
 For further information consult the website [www.asercom.org](http://www.asercom.org).

# MODELS DESIGNATION

## Compressor

**NR L 3 100 360 Y**

Series	
Semi-hermetic screw compressor	
Application	
H	High/medium evaporating temperature
L	Low evaporating temperature
Compressor size	
Compressor size	
Motor size	
Motor size	
Displacement	
120+538 m <sup>3</sup> /h at 50Hz	
Oil charge	
POE	

# WORKING LIMITS

## R134a

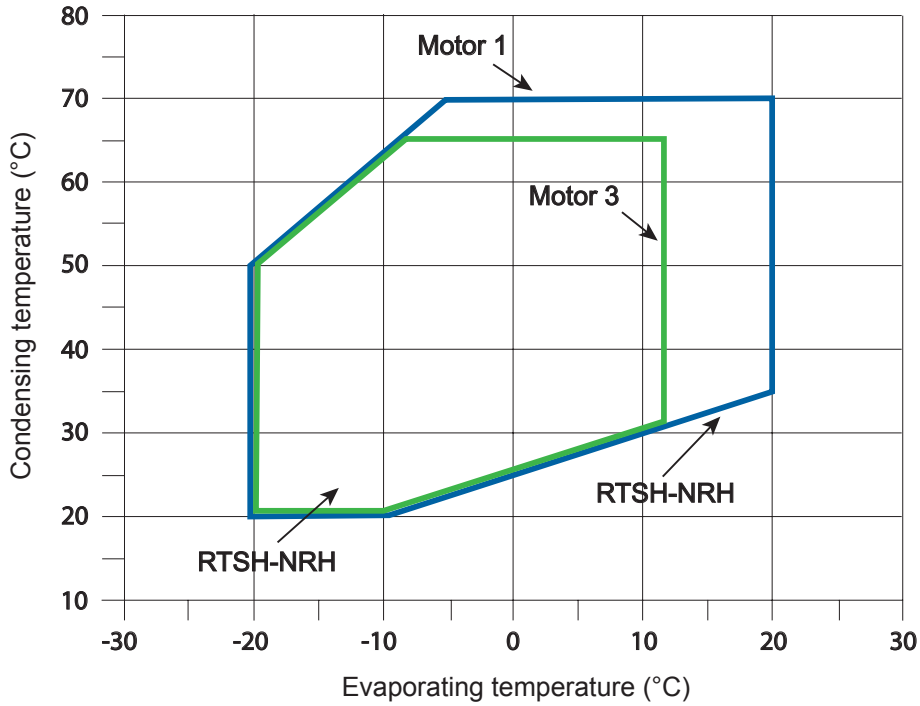

## R407A - R407F

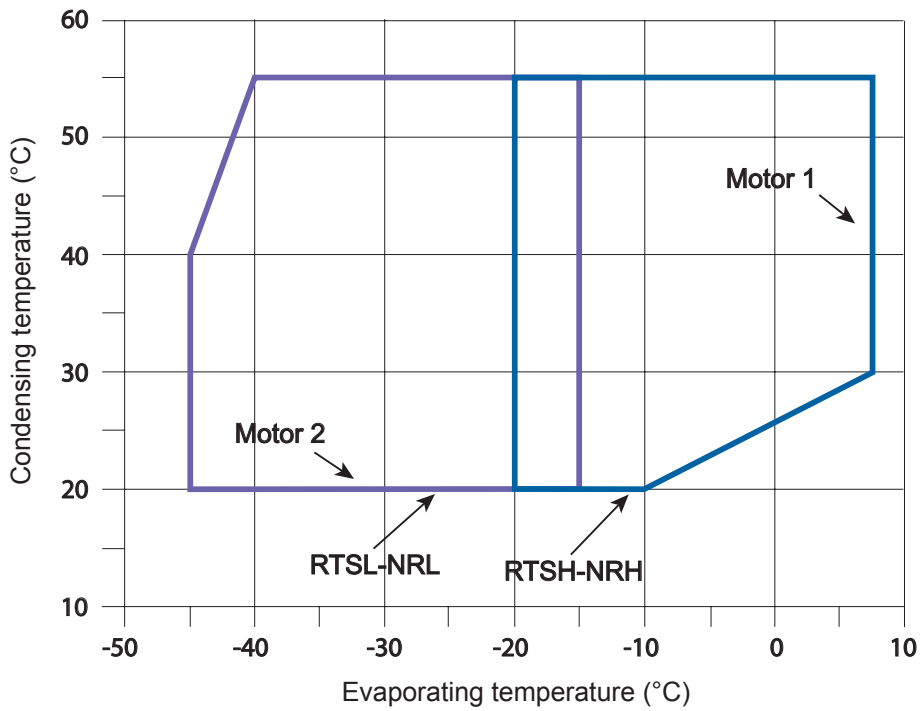

Suction gas superheating 10K - without liquid subcooling  
 For operating limits where additional oil cooler is required, refer the Frascold Selection Software.  
 Economiser operation - the maximum condensing temperature could be limited

# WORKING LIMITS

## R404A - R507A

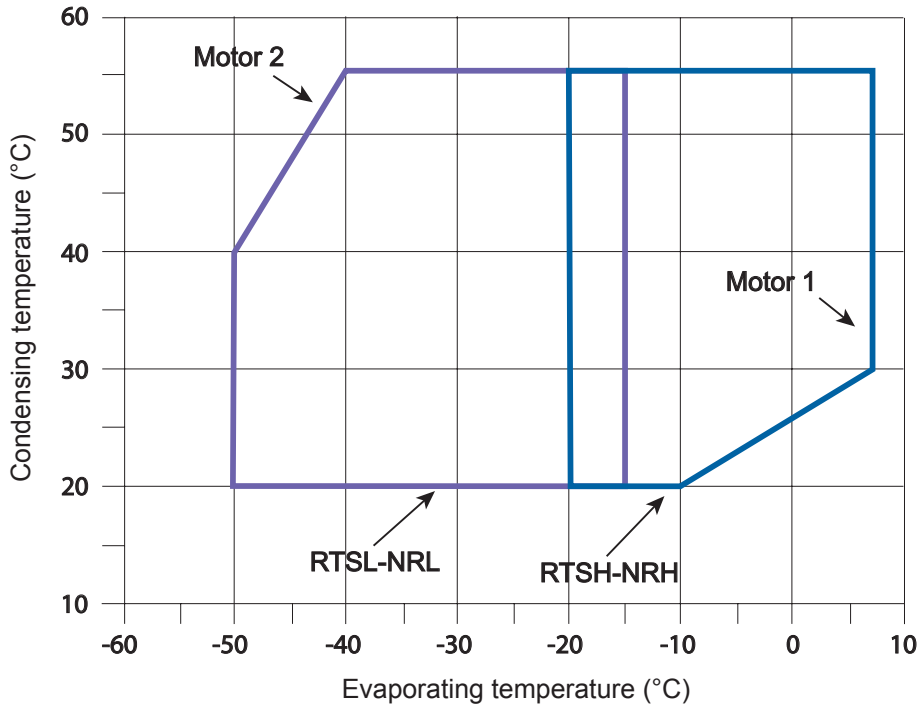

## R22

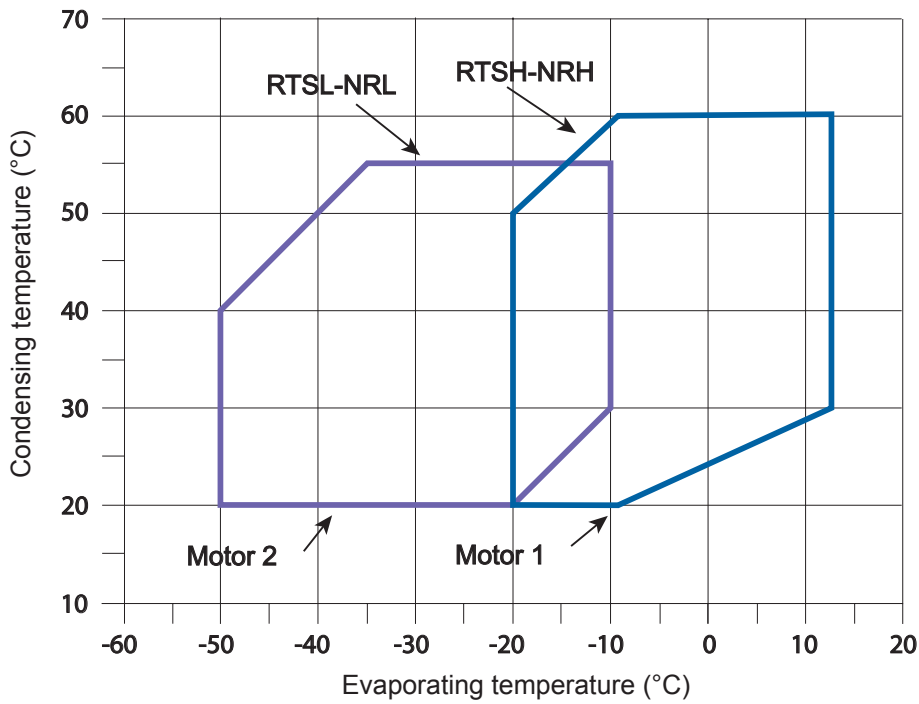

Suction gas superheating 10K - without liquid subcooling  
 For operating limits where additional oil cooler is required, refer the Frascold Selection Software.  
 Economiser operation - the maximum condensing temperature could be limited

## RTSH models - High / medium temperature range - Motor 1

Product specification		RTSH-			
		40-120Y	50-150Y	60-186Y	70-210Y
Cooling capacity (kW - 50 Hz)	R134a	37	46	56	64
	R404A	55	70	87	99
	R407F	57	73	89	102
	R407A	53	68	83	95
	R22	62	78	94	104
Nominal motor power	HP	40	50	60	70
	kW	30	37	45	52
Displacement (m <sup>3</sup> /h)	50 Hz	120	150	186	210
	60 Hz	144	180	223	252
Weight	kg	180	230	250	298
Nominal capacity steps	%	100% - 50%			
Suction line	mm	54	54		
	pollici	2 $\frac{1}{8}$	2 $\frac{1}{8}$	3 $\frac{1}{8}$	3 $\frac{1}{8}$
Discharge line	mm	42	42	54	54
	pollici	1 $\frac{5}{8}$	1 $\frac{5}{8}$	2 $\frac{1}{8}$	2 $\frac{1}{8}$
Starting current (A)	PWS - $\Delta$ / $\Delta$	266	319	298	373
	DOL	438	527	518	600
Max operating current	A	85	108	122	140

Data reference: evaporating temperature -10°C; condensing temperature 45°C;

Suction gas superheating 10K; without liquid subcooling.

Standard motor: 400V / 3 / 50 Hz // 460V / 3 / 60 Hz.

Motor connection: PWS o DOL.

## RTSL models - Low temperature range - Motor 2

Product specification		RTSL-			
		30-120Y	40-150Y	50-186Y	60-210Y
Cooling capacity (kW - 50 Hz)	R134a				
	R404A	30	38	48	52
	R407F	31	39	50	54
	R407A	29	36	46	50
	R22	30	38	46	52
Nominal motor power	HP	30	40	50	60
	kW	22	30	37	45
Displacement (m <sup>3</sup> /h)	50 Hz	120	150	186	210
	60 Hz	144	180	223	252
Weight	kg	175	226	244	290
Nominal capacity steps	%	100% - 50%			
Suction line	mm	54	54	79.4	79.4
	pollici	2 $\frac{1}{8}$	2 $\frac{1}{8}$	3 $\frac{1}{8}$	3 $\frac{1}{8}$
Discharge line	mm	42	42	54	54
	pollici	1 $\frac{5}{8}$	1 $\frac{5}{8}$	2 $\frac{1}{8}$	2 $\frac{1}{8}$
Starting current (A)	PWS - $\Delta$ / $\Delta$	201	235	203	256
	DOL	239	388	330	440
Max operating current	A	51	68	89	108

Data reference: evaporating temperature -35°C; condensing temperature 40°C;

Suction gas superheating 10K; without liquid subcooling; ECO.

Standard motor: 400V / 3 / 50 Hz // 460V / 3 / 60 Hz.

Motor connection: PWS o DOL.



## NRH models - High / medium temperature range - Motor 1

Product specification	Modelli	NRH-				NRH6-			
		80-240Y	90-270Y	100-300Y	120-360Y	110-316Y	125-372Y	140-428Y	160-468Y
Cooling capacity (kW - 50 Hz)	R134a	75	84	93	113	101	120	141	154
	R404A	116	131	146	172	161	190	218	238
	R407F	119	135	150	177	167	197	225	247
	R407A	111	126	140	165	155	185	209	230
	R22	124	139	155	184	170	196	229	250
Nominal motor power	HP	80	90	100	120	110	125	140	160
	kW	60	67	75	90	83	95	105	120
Displacement (m <sup>3</sup> /h)	50 Hz	240	270	300	360	316	372	428	468
	60 Hz	288	324	360	432	380	445	515	562
Weight	kg	320	325	348	353	730	734	742	749
Nominal capacity steps	%	100% - 75% - 50%							
Suction line	mm	79.4	79.4	79.4	79.4	104	104	104	104
	pollici	3 $\frac{1}{8}$	3 $\frac{1}{8}$	3 $\frac{1}{8}$	3 $\frac{1}{8}$	4 $\frac{1}{8}$	4 $\frac{1}{8}$	4 $\frac{1}{8}$	4 $\frac{1}{8}$
Discharge line	mm	54	54	67	67	79.4	79.4	79.4	79.4
	pollici	2 $\frac{1}{8}$	2 $\frac{1}{8}$	2 $\frac{3}{8}$	2 $\frac{3}{8}$	3 $\frac{1}{8}$	3 $\frac{1}{8}$	3 $\frac{1}{8}$	3 $\frac{1}{8}$
Starting current (A)	PWS - $\Delta$ / $\Delta$	423	401	492	559	434	530	587	729
	DOL	698	656	834	915	720	838	921	1114
Max operating current	A	157	177	194	230	184	218	245	282

Data reference: evaporating temperature -10°C; condensing temperature 45°C;

Suction gas superheating 10K; without liquid subcooling.

Standard motor: 400V / 3 / 50 Hz // 460V / 3 / 60 Hz.

Motor connection: PWS o DOL.

## NRL models - Low temperature range - Motor 2

Product specification	Modelli	NRL-				NRL6-	
		70-240Y	80-270Y	90-300Y	100-360Y	125-428Y	160-538Y
Cooling capacity (kW - 50 Hz)	R134a						
	R404A	63	72	79	96	118	139
	R407F	65	74	81	99	120	144
	R407A	61	69	76	92	112	134
	R22	60	68	75	91	113	136
Nominal motor power	HP	70	80	90	100	125	160
	kW	52	60	67	75	95	120
Displacement (m <sup>3</sup> /h)	50 Hz	240	270	300	360	428	538
	60 Hz	288	324	360	432	513	645
Weight	kg	316	317	340	344	736	749
Nominal capacity steps	%	100% - 75% - 50%					
Suction line	mm	79.4	79.4	79.4	79.4	104	104
	pollici	3 $\frac{1}{8}$	3 $\frac{1}{8}$	3 $\frac{1}{8}$	3 $\frac{1}{8}$	4 $\frac{1}{8}$	4 $\frac{1}{8}$
Discharge line	mm	54	54	67	67	79.4	79.4
	pollici	2 $\frac{1}{8}$	2 $\frac{1}{8}$	2 $\frac{3}{8}$	2 $\frac{3}{8}$	3 $\frac{1}{8}$	3 $\frac{1}{8}$
Starting current (A)	PWS - $\Delta$ / $\Delta$	298	373	423	401	530	587
	DOL	518	600	698	656	838	921
Max operating current	A	122	140	157	177	198	221

Data reference: evaporating temperature -35°C; condensing temperature 40°C;

Suction gas superheating 10K; without liquid subcooling; ECO.

Standard motor: 400V / 3 / 50 Hz // 460V / 3 / 60 Hz.

Motor connection: PWS o DOL.

## RTSH models - High / medium temperature range - Motor 3

Product specification		RTSH-			
		30-120Y	40-150Y	50-186Y	60-210Y
Cooling capacity (kW - 50 Hz)	R134a	37	46	56	64
Nominal motor power	HP	30	40	50	60
	kW	22	30	37	45
Displacement (m <sup>3</sup> /h)	50 Hz	120	150	186	210
	60 Hz	144	180	223	252
Weight	kg	175	226	244	290
Nominal capacity steps	%	100% - 50%			
Suction line	mm	54	54	79.4	79.4
	pollici	2 $\frac{1}{4}$	2 $\frac{1}{4}$	3 $\frac{1}{8}$	3 $\frac{1}{8}$
Discharge line	mm	42	42	54	54
	pollici	1 $\frac{5}{8}$	1 $\frac{5}{8}$	2 $\frac{1}{8}$	2 $\frac{1}{8}$
Starting current (A)	PWS - $\Delta$ / $\Delta$	201	235	203	256
	DOL	239	388	330	440
Max operating current	A	51	68	89	108

Data reference: evaporating temperature -10°C; condensing temperature 45°C;

Suction gas superheating 10K; without liquid subcooling.

Standard motor: 400V / 3 / 50 Hz // 460V / 3 / 60 Hz.

Motor connection: PWS o DOL.

## NRH models - High / medium temperature range - Motor 3

Product specification	Modelli	NRH-				NRH6-			
		70-240Y	80-270Y	90-300Y	100-360Y	110-398Y	115-428Y	125-468Y	140-538Y
Cooling capacity (kW - 50 Hz)	R134a	76	85	94	114	129	142	155	178
Nominal motor power	HP	70	80	90	100	110	115	125	140
	kW	52	60	67	75	83	87	95	105
Displacement (m <sup>3</sup> /h)	50 Hz	240	270	300	360	398	428	468	538
	60 Hz	288	324	360	432	478	513	562	645
Weight	kg	316	317	340	344	731	732	735	738
Nominal capacity steps	%	100% - 75% - 50%							
Suction line	mm	79.4	79.4	79.4	79.4	104	104	104	104
	pollici	3 $\frac{1}{8}$	3 $\frac{1}{8}$	3 $\frac{1}{8}$	3 $\frac{1}{8}$	4 $\frac{1}{8}$	4 $\frac{1}{8}$	4 $\frac{1}{8}$	4 $\frac{1}{8}$
Discharge line	mm	54	54	67	67	79.4	79.4	79.4	79.4
	pollici	2 $\frac{1}{8}$	2 $\frac{1}{8}$	2 $\frac{1}{2}$	2 $\frac{1}{2}$	3 $\frac{1}{8}$	3 $\frac{1}{8}$	3 $\frac{1}{8}$	3 $\frac{1}{8}$
Starting current (A)	PWS - $\Delta$ / $\Delta$	298	373	423	401	434	434	530	587
	DOL	518	600	698	656	720	720	838	921
Max operating current	A	122	140	157	177	180	184	198	221

Data reference: evaporating temperature -10°C; condensing temperature 45°C;

Suction gas superheating 10K; without liquid subcooling.

Standard motor: 400V / 3 / 50 Hz // 460V / 3 / 60 Hz.

Motor connection: PWS o DOL.

# RTSH/L- 120 RTSH/L- 150

## Dimensional drawing

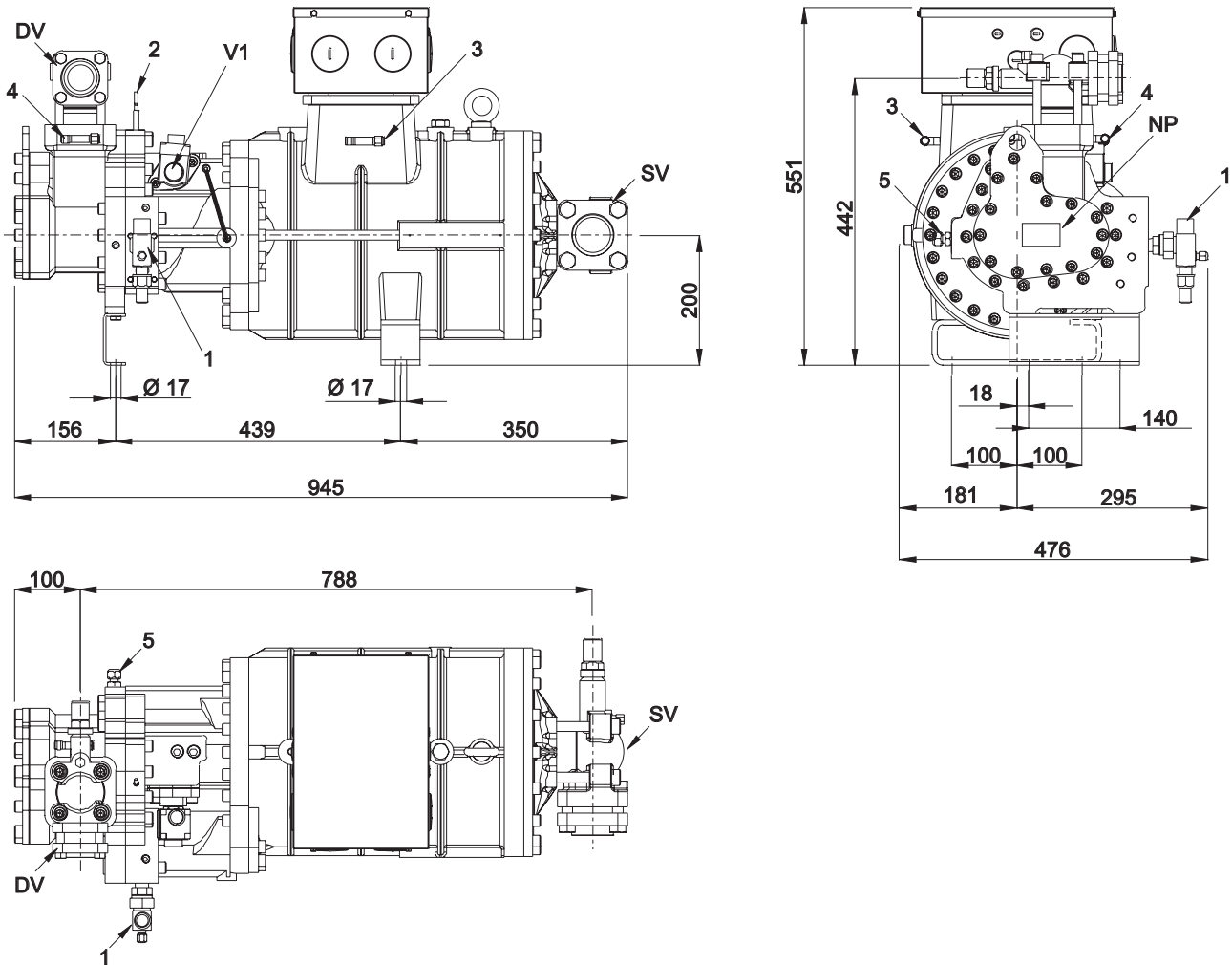

### DRAWING NOTES

1	Oil injection connection
2	Discharge temperature sensor
3	Low pressure connection (LP)
4	High pressure connection (HP)
5	Economiser/liquid injection connection
V1	Capacity control valve (step 1)
NP	Nameplate
DV	Discharge valve (ø 1" 5/8 - 42.0 mm)
SV	Suction valve (ø 2" 1/8 - 54.0 mm)

# RTSH/L- 186 RTSH/L- 210

## Dimensional drawing

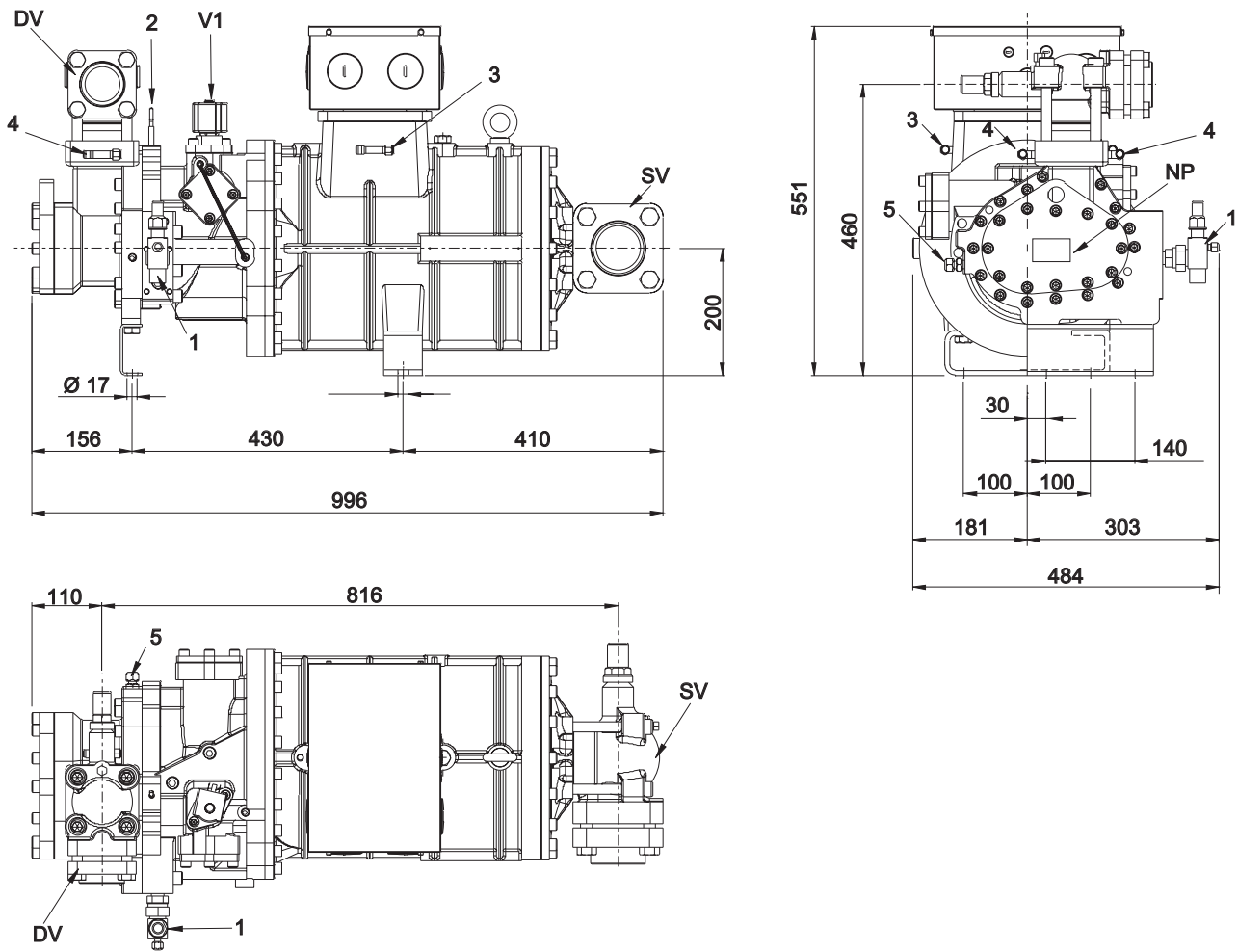

### DRAWING NOTES

1	Oil injection connection
2	Discharge temperature sensor
3	Low pressure connection (LP)
4	High pressure connection (HP)
5	Economiser/liquid injection connection
V1	Capacity control valve (step 1)
NP	Nameplate
DV	Discharge valve ( $\varnothing 2\frac{1}{8}$ - 54.0 mm)
SV	Suction valve ( $\varnothing 3\frac{1}{8}$ - 79.4 mm)

# NRH/L- 240 NRH/L- 270

## Dimensional drawing

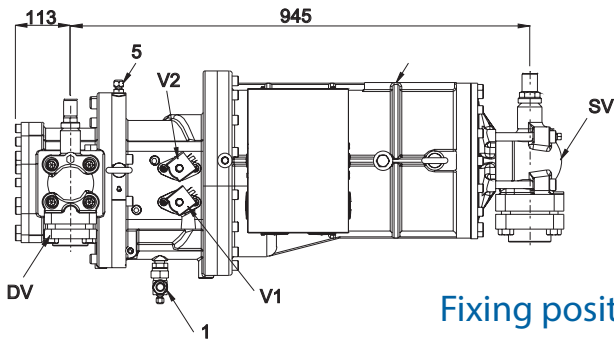
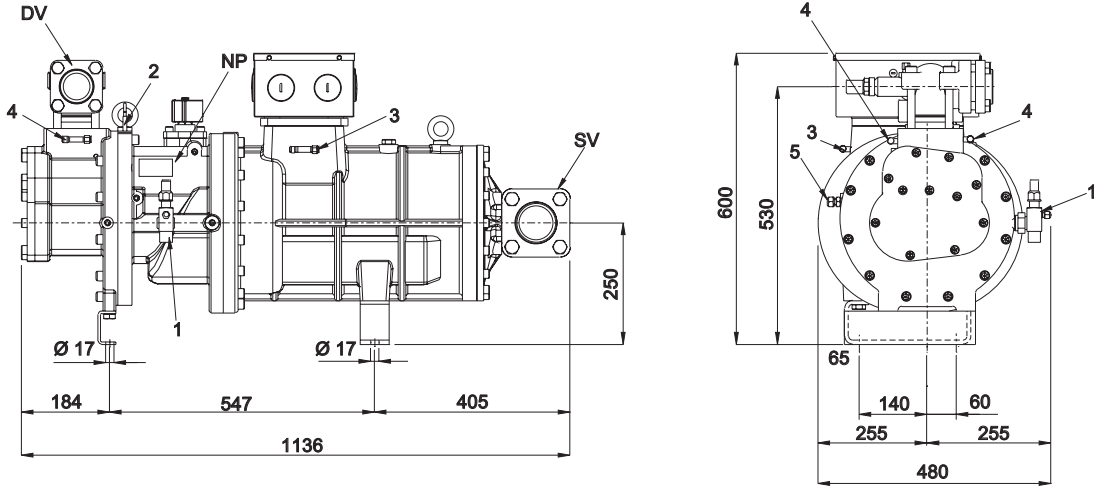

## Fixing positions

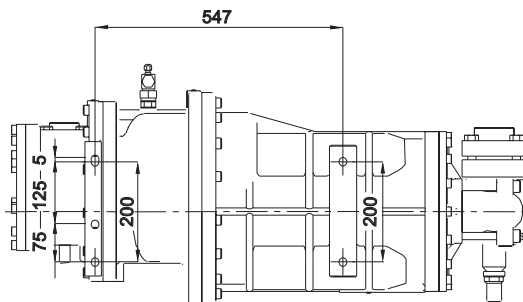

## DRAWING NOTES

1	Oil injection connection
2	Discharge temperature sensor
3	Low pressure connection (LP)
4	High pressure connection (HP)
5	Economiser/liquid injection connection
V1	Capacity control valve (step 1)
V2	Capacity control valve (step 2)
NP	Nameplate
DV	Discharge valve (Ø 2" 1/8 - 54.0 mm)
SV	Suction valve (Ø 3" 1/8 - 79.4 mm)

# NRH/L- 300

## Dimensional drawing

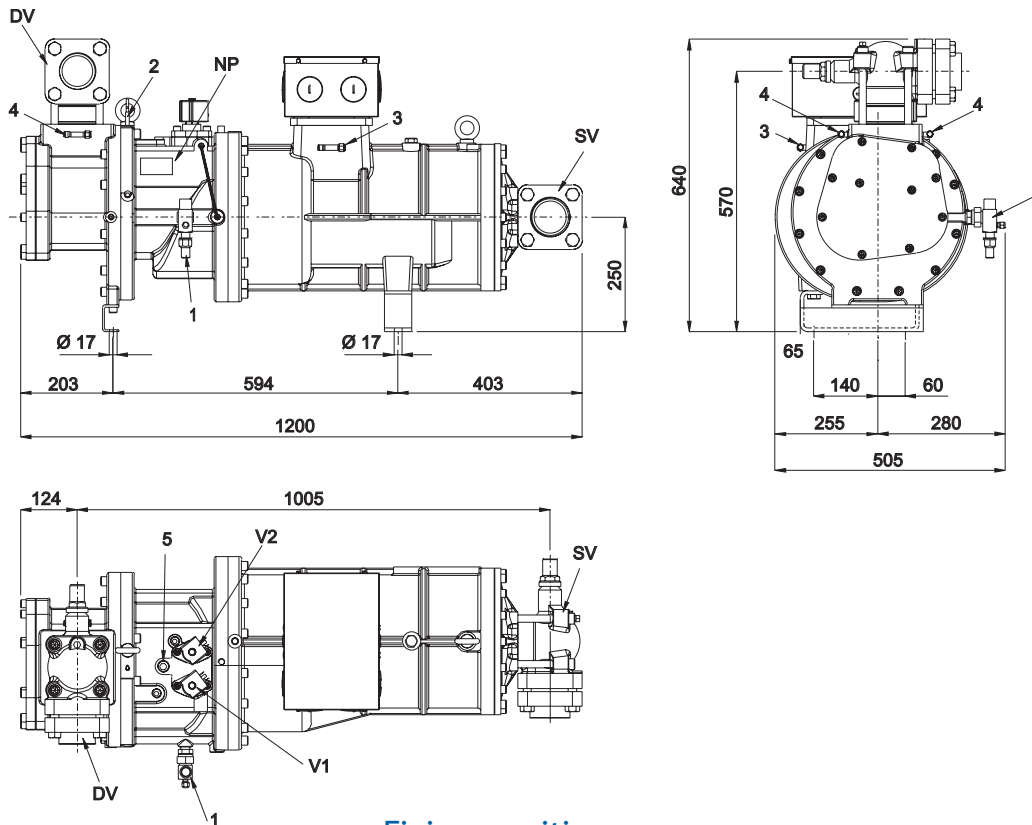

## Fixing positions

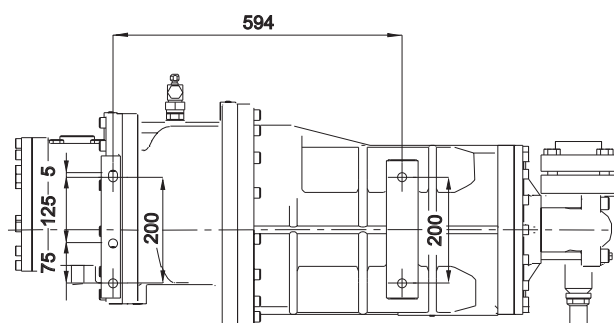

## DRAWING NOTES

1	Oil injection connection
2	Discharge temperature sensor
3	Low pressure connection (LP)
4	High pressure connection (HP)
5	Economiser/liquid injection connection
V1	Capacity control valve (step 1)
V2	Capacity control valve (step 2)
NP	Nameplate
DV	Discharge valve (ø 2" 5/8 - 67.0 mm)
SV	Suction valve (ø 3" 1/8 - 79.4 mm)

# NRH/L- 360

## Dimensional drawing

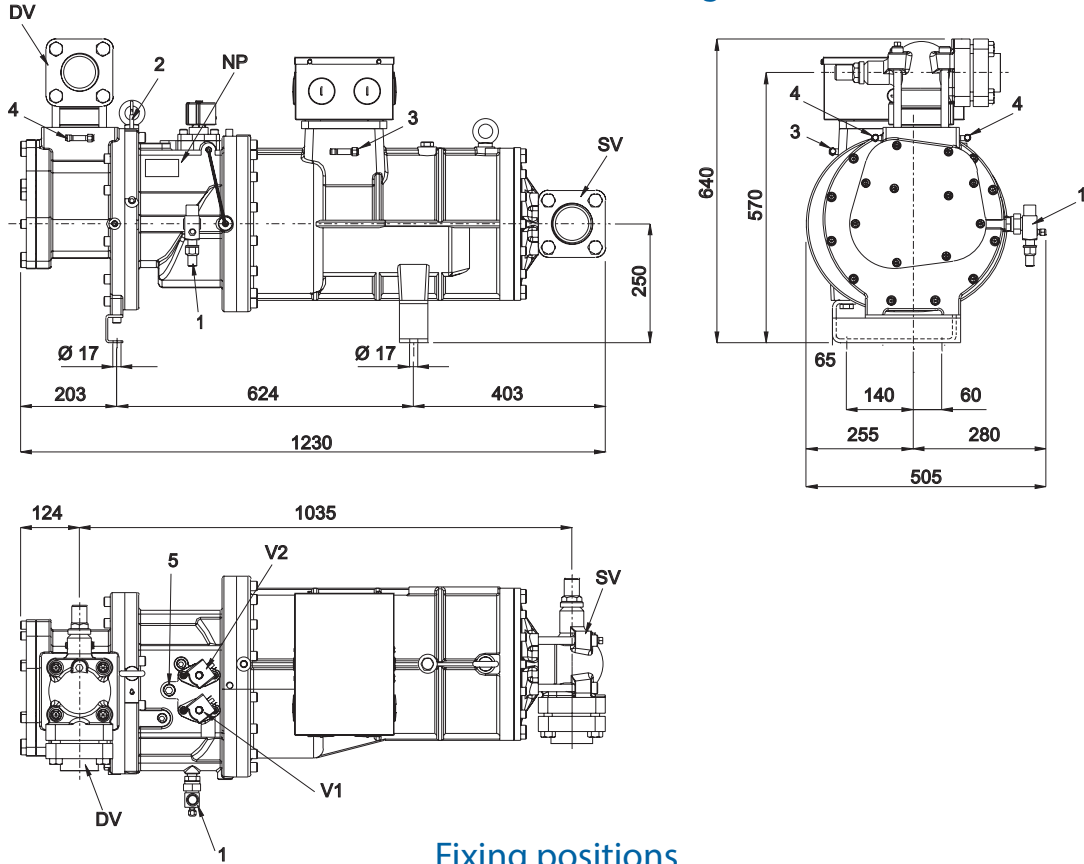

## Fixing positions

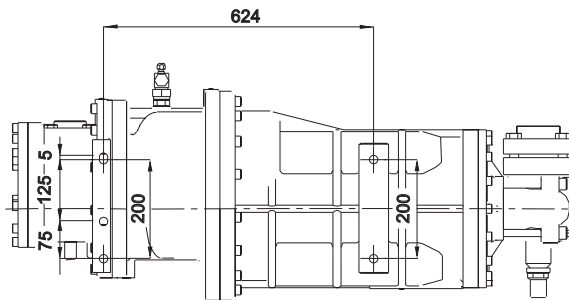

### DRAWING NOTES

1	Oil injection connection
2	Discharge temperature sensor
3	Low pressure connection (LP)
4	High pressure connection (HP)
5	Economiser/liquid injection connection
V1	Capacity control valve (step 1)
V2	Capacity control valve (step 2)
NP	Nameplate
DV	Discharge valve (ø 2" 5/8 - 67.0 mm)
SV	Suction valve (ø 3" 1/8 - 79.4 mm)



# NR\_6

## Dimensional drawing

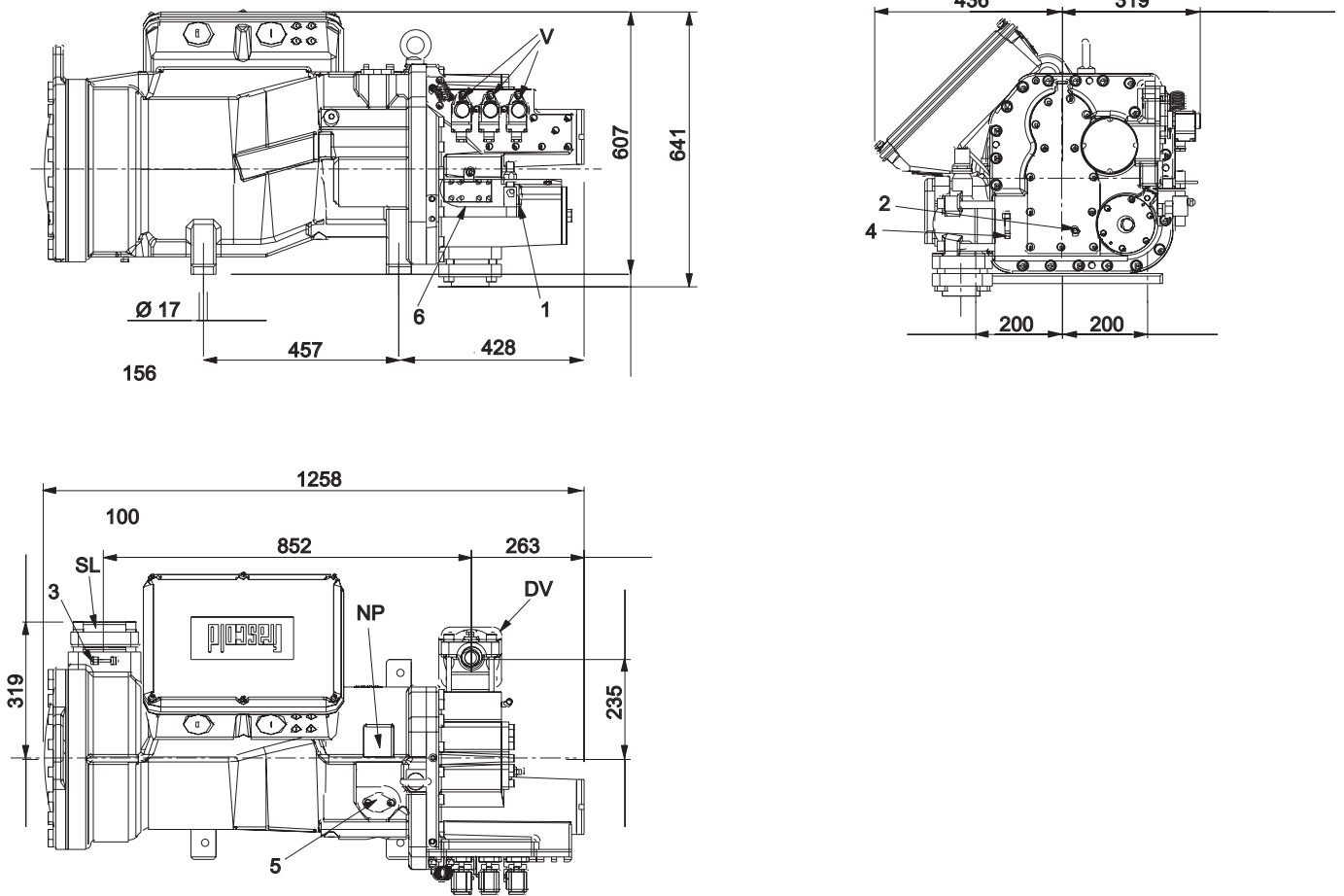

### DRAWING NOTES

1	Oil injection connection
2	Discharge temperature sensor
3	Low pressure connection (LP)
4	High pressure connection (HP)
5	Economiser/liquid injection connection
6	Flowswitch
V	Capacity control valve
NP	Nameplate
DV	Discharge valve ( $\varnothing 4'' \frac{1}{8} - 104 \text{ mm}$ )
SL	Suction connection ( $\varnothing 3'' \frac{1}{8} - 79.4 \text{ mm}$ )

# OIL INJECTION CIRCUIT

Circuit for NR\_6

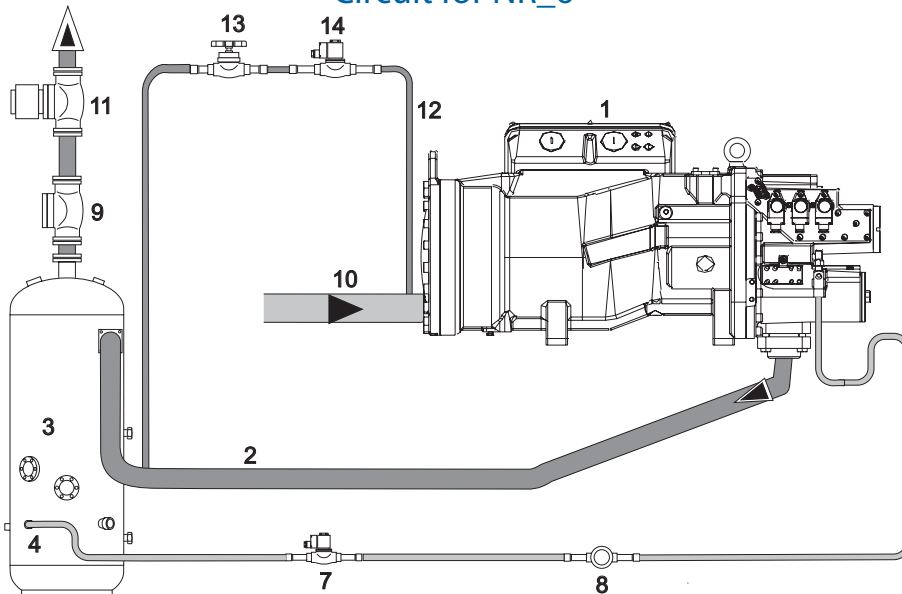

Circuit for all others models

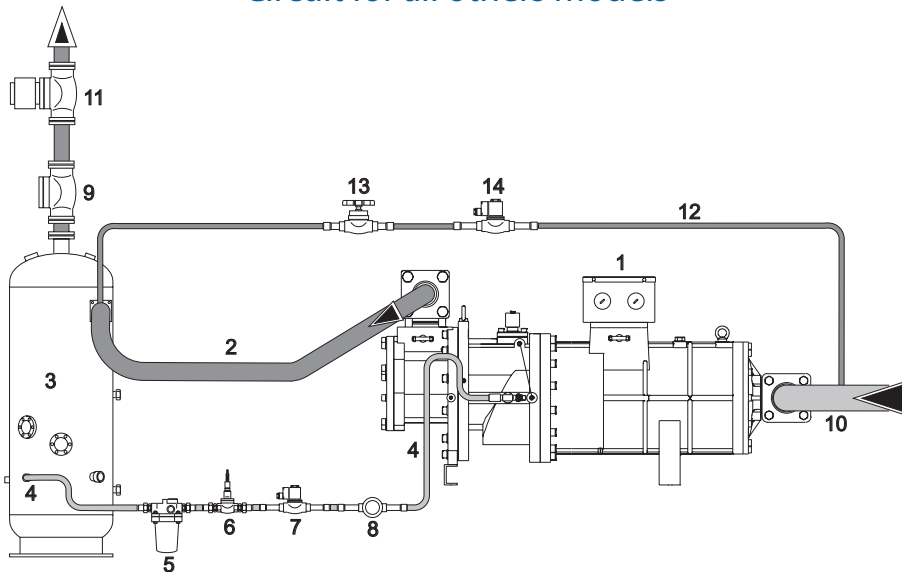

## DRAWING NOTES

1	Compressor
2	Discharge line
3	Remote oil separator
4	Oil return line
5	Oil filter
6	Oil flow switch
7	Oil solenoid valve
8	Sight glass
9	Check valve
10	Suction line
11	Discharge pressure regulating valve
12	Pressure equalization line
13	Shut-off valve
14	Solenoid valve

# OIL SEPARATOR

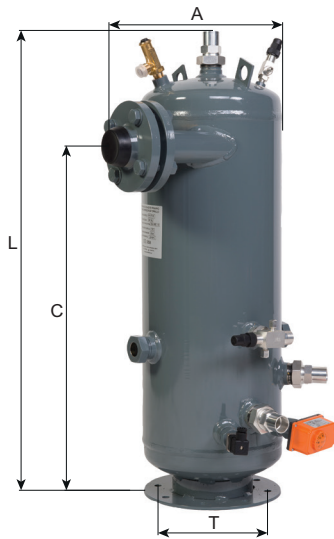

Description	
1	Refrigerant outlet
2	Service valve
3	Safety valve
4	Refrigerant inlet
5	Level detector connection
6	Oil heater
7	Oil thermostat
8	Oil inlet
9	Oil outlet



Models	Maximum suction volume flow (theoretical displacement)				
	High temperature range (m³/h)		Medium temperature range (m³/h)		Low temperature range (m³/h)
	R134a	R404A - R507A	R134a	R404A - R507A	
T00WP200T	250	220	300	300	300
T00WP201T	579	438	660	619	660
T00WP202T	1158	840	1317	1180	1317
T00WP203T	1319	1179	1317	1317	1317
T00WP204T	2050	1900	2300	2100	2500
T00WP205T	2200	2080	2420	2250	2610

Code	T00WP200T	T00WP201T	T00WP202T	T00WP203T	T00WP204T	T00WP205T
A (mm)	388	494	672	775	781	984
T (mm)	220	280	430	530	530	640
C (mm)	679	975	1222	1174	1924	1585
L (mm)	914	1264	1685	1667	2647	2063
Total volume (L)	40	80	288	385	655	900
Oil volume (L)	18	40	90	140	250	320
N° oil heater	1	2	3	3	4	4
N° MAX comp.	2	3	6	6	6	6
Refrig. inlet	Adapter 1 ¼"x1 ½"	DN 65	DN 100	DN 100	DN 125	DN 125
Refrig. outlet	DN 50	DN 65	DN 100	DN 100	DN 125	DN 125
Oil outlet	Adapter 1 ¼"x1 ½"	Adapter 1 ¼"x1 ½"	Adapter 2 ¼"x1 ½"	Adapter 2 ¼"x2 ½"	Conn. 3 ⅛" ODS	Conn. 3 ⅛" ODS
Safety valve connection	½" NPT	½" NPT	2x½" NPT	2x½" NPT	2x½" NPT	2x½" NPT
Oil filling inlet	1 ¼"x ⅜"	1 ¼"x ⅜"	1 ¼"x ⅜"	1 ¼"x ⅜"	1 ¼"x ⅜"	1 ¼"x ⅜"

# FRASCOLD®

Company with more than 75 years of experience that manufactures compressor for refrigeration and air conditioning industries. The great experience gained over the years provides cutting-edge products and solutions, in line with the latest market demand. Additional or different equipment and devices are meant to meet the peculiarity of each application worldwide, always paying specific attention to the energy saving and in full respect of the environment. Furthermore all quality and construction directives indicated by the relevant authorities are strictly followed.

## **FRASCOLD SpA**

Via B. Melzi 105 - 20027 Rescaldina (MI) Italy  
Tel. +39 0331 742201 - Fax +39 0331 576102  
mail: [frascold@frascold.it](mailto:frascold@frascold.it) - web: [www.frascold.it](http://www.frascold.it)